

X2 Micro OCS Datasheet

Model A Built-In I/O: 12 Digital Inputs, 12 Digital Outputs, 4 Analog Inputs, 2 Analog Outputs

Model R Built-In I/O: 12 Digital Inputs, 6 Relay Outputs, 2 PWM Outputs, 4 Analog Inputs, 2 Analog Outputs

MAN1131_22_EN_X2_DS



HG-470

Part Numbers

| | |
|--------------------------------------|--------|
| Model R: Relay & Solid State Outputs | HE-X2R |
| Model A: Solid State Outputs | HE-X2A |

User Manual and Add-Ons

Find the documents via the [Documentation Search](#).

| Part # | Description |
|-------------|---|
| MAN1130 | HE-X2 User Manual |
| HE-BAT009 | 3V Lithium Coin Battery |
| HE-XCK | Programming Cable Kit |
| HE-PRGMINI | Standalone Mini-USB Programming Cable |
| HE-FBD001 | Ferrite core for filtering out electrical noise. |
| HE200MJ2TRM | Adapter, RJ45 (8P8C) male to 8-position terminal strip. |

Battery Maintenance

The X2 Micro OCS has an advanced battery system that uses a packaged lithium coin battery. The battery powers the real time clock when power is removed, and it is needed for register data retention. Please see manual **MAN1130** via the [Documentation Search](#) for more details on battery replacement.

Table of Contents

| | |
|--|-----------|
| Part Numbers | 1 |
| User Manual and Add-Ons | 1 |
| Battery Maintenance | 1 |
| TECHNICAL SPECIFICATIONS | 2 |
| General Specifications | 2 |
| Control and Logic | 2 |
| User Interface | 3 |
| Connectivity | 3 |
| Testing | 3 |
| CONTROLLER OVERVIEW | 4 |
| Overview of OCS | 4 |
| Power Wiring | 5 |
| DIGITAL & RELAY I/O SPECIFICATIONS | 6 |
| Digital DC Input: Models R & A | 6 |
| Model A: Digital DC Outputs, Sourcing | 6 |
| Model R: Digital DC Outputs, Sinking, Sourcing | 7 |
| Relay Outputs: Model R | 7 |
| ANALOG I/O SPECIFICATIONS | 8 |
| Analog Inputs, Models R & A | 8 |
| Analog Outputs, Models R & A | 8 |
| WIRING: INPUTS AND OUTPUTS | 9 |
| Analog Inputs Information | 9 |
| Digital Inputs | 9 |
| Positive Logic vs. Negative Logic | 9 |
| Inserting and Removing Connectors | 10 |
| Built-In I/O: Models R & A | 10 |
| J1 & J2 WIRING | 11 |
| J3 WIRING | 15 |
| COMMUNICATIONS | 16 |
| Serial Communication | 16 |
| Ethernet | 16 |
| CAN Communications | 17 |
| Discrete Wiring | 17 |
| DIMENSIONS & INSTALLATION | 18 |
| X2 Dimensions | 18 |
| Installation Procedure | 19 |
| SAFETY & MAINTENANCE | 20 |
| Warnings | 20 |
| FCC Compliance | 20 |
| Precautions | 20 |

TECHNICAL SPECIFICATIONS

General Specifications

| | |
|------------------------------|--|
| Primary Power Range | 24VDC \pm 20% |
| Typical power-backlight 100% | 64mA @ 24V (1.53W) |
| Power Backlight Off | 15mA @ 24V (0.36W) |
| Inrush Current | 30A for < 1ms |
| Real Time Clock | Battery backed; lithium coin cell CR2450 |
| Clock Accuracy | \pm 90 Secs/Month |
| Relative Humidity | 5 to 95% Non-condensing |
| Operating Temperature | -10°C to +60°C |
| Storage Temperature | -20°C to +70°C |
| Weight | 0.75 lb/ 340g |
| Mounting Clips | 4 composite type |
| Housing Material | Polycarbonate, UL rated |
| Panel Seal | Silicone rubber |
| Packaging | 100% recyclable paper fiber materials |

Control and Logic

| | |
|--------------------------|---|
| Control Language Support | Advanced ladder logic; Full IEC 61131-3 languages |
| Logic Program Size | 256kB |
| Non-Retentive Memory | 128kB |
| Internal Storage Memory | 16Mb |
| Total Program Memory | 2.5Mb |
| Logic Scan Rate | 0.4ms/kB |
| %I (Digital Inputs) | 1024 |
| %Q (Digital Outputs) | 1024 |
| %AI (Analog Inputs) | 256 |
| %AQ (Analog Outputs) | 256 |
| %M (Retentive Bits) | 1024 |
| %T (Temporary Bits) | 1024 |
| %R (Retentive Registers) | 5000 |
| %D (Display Bits) | 250 |
| %K (Key Bit) | 10 |
| %S (Status Bits) | 16 |

User Interface

| | |
|---------------------------------|--|
| Display | 2.2" Monochrome LCD |
| Resolution | 128 x 64 pixels |
| Backlight | LED |
| Backlight Lifetime | 50,000 hrs |
| Backlight Control | Software controlled (ON/OFF) |
| User-Programmable Screens/Pages | 250 |
| Number of Objects/Screens | 15 |
| Screen Memory | 256kB |
| Keypad | Membrane type switches w/metal dome |
| Tactile Feedback | Yes |
| Number of Keys | 4 Soft keys + 16 numeric/function keys |

Connectivity

| | |
|----------------------|--|
| Serial Ports | 1 x RS-232, 1 x RS-485 |
| Serial Protocols | Modbus RTU, GE SNP, GPS |
| RS-485 Terminations | On-board, software controlled |
| Mini USB | Programming Only |
| CAN Hardware | Non-isolated |
| CAN Port Connector | RJ45 (red) |
| CANSpeeds Support | 125kb, 250kb, 500kb, 1MB/sec. |
| CAN Port Termination | On-board, software controlled |
| CAN Protocols | CsCAN |
| Removable Memory In | microSD, SDHC, SDXC in FAT32 format, support for 32GB max. Application Updates, Datalogging... |

Testing

| | |
|--------------------------|--|
| Shock | IEC 60068-2-27 |
| Vibration | IEC 60068-2-6 |
| UL Environmental Ratings | Type 1, 4X indoor use only, 12, 12k & 13 |
| Certifications (UL/CE) | North America Europe |

CONTROLLER OVERVIEW

Overview of OCS

1. Keypad
2. High Capacity microSD slot
3. RS-232/RS-485 Serial Port
4. CAN Port (Via RJ45)
5. USB Mini-B Port
6. Analog I/O
7. DC Inputs
8. DC Outputs
9. DC Power



NOTE: See "Precautions" on page 20 about USB and grounding.

Power Wiring

NOTE: The Primary Power Range is 10VDC to 30VDC.

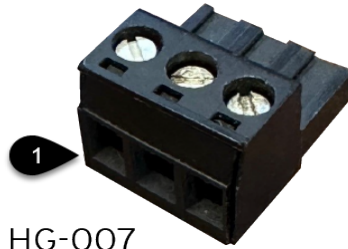

HG-007

| Primary Power Port Pins | | |
|-------------------------|--------|----------------------------|
| PIN | Signal | Description |
| 1 | Ground | Frame/Earth Ground |
| 2 | DC- | Input Power Supply Ground |
| 3 | DC+ | Input Power Supply Voltage |

Wiring Details

- Solid/Stranded Wire: 12-24 AWG (2.5-0.2mm)
- Strip length: 0.28" (7mm)
- Torque, Terminal Hold-Down Screws: 4.5 – 7 in-lbs (0.50 – 0.78 Nm)

DC- is internally connected to I/O V-, but is isolated from CAN V-. A Class 2 power supply must be used.

Power Up

1. **Optional:** Attach ferrite core with a minimum of two turns of the DC+ and DC- signals from the DC supply that is powering the controllers.

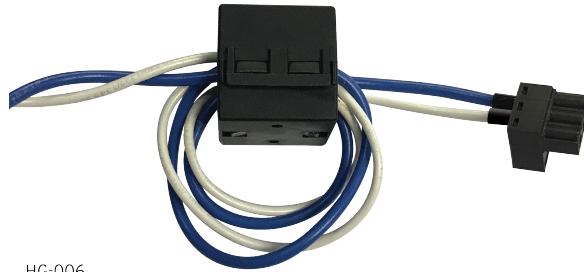

HG-006

2. Connect to earth ground.
3. Apply recommended power.

DIGITAL & RELAY I/O SPECIFICATIONS

Digital DC Input: Models R & A

| | | |
|---------------------------|---|----------------|
| Inputs per Module | 12 including 4 configurable HSC inputs | |
| Commons per Module | 1 | |
| Input Voltage Range | 12VDC / 24VDC | |
| Absolute Max. Volt. | 30VDC Max. | |
| Input Impedance | 10kΩ | |
| Input Current | Positive Logic | Negative Logic |
| Upper Threshold | 0.8mA | -1.6mA |
| Lower Threshold | 0.3mA | -2.1mA |
| Max. Upper Threshold | 8VDC | |
| Min. Lower Threshold | 3VDC | |
| OFF to ON Response | 0.1ms | |
| ON to OFF Response | 0.1ms | |
| Number of Counters | 4 | |
| Maximum Counter Frequency | 10kHz | |
| Counter Accumulator Size | 32-bits each | |
| Counter Modes Supported | Totalizer, quadrature, pulse measurement, frequency measurement, set-point controlled outputs | |

Model A: Digital DC Outputs, Sourcing

| | | |
|------------------------------------|---|-------------------|
| Outputs per Module | 12 Including 2 Configurable PWM/HSC Outputs | |
| Commons per Module | 2 | |
| Type | Sourcing | |
| Absolute Max. Voltage | 28VDC | |
| Output Protection | Short Circuit, Thermal, Undervoltage | |
| Max. Voltage Drop at Rated Current | 0.25VDC | |
| Max Output per Point: Sourcing | 0.5A @ 24VDC | |
| | Min | Max |
| OFF to ON Time (typical) | 300ns | 500ns + Scan Time |
| ON to OFF Time (typical) | 300ns | 475ns = Scan Time |
| PWM Out Maximum Frequency | 65kHz | |
| Rise Time | 150ns Max | |
| Fall Time | 150ns Max | |

Model R: Digital DC Outputs, Sinking, Sourcing

| | | |
|--|-----------------------------|-------------------------|
| Outputs per Module | 2 (PWM or HSC) | |
| Commons per Module | 1 | |
| Type | Sinking | |
| Absolute Max. Voltage | 28VDC | |
| Output Protection | Short Circuit | |
| Max. Output per Point: Sinking | 0.5A | |
| Max. Output per Point: Sourcing | 2.4mA @ 24V | |
| Max. Voltage Drop at Rated Current | 0.25VDC | |
| Max Outrush | 650mA | |
| | Min | Max |
| OFF to ON Time (typical) | 2.2 μ s | 2.2 μ s + Scan Time |
| ON to OFF Time (typical) | 13 μ s | 13 μ s + Scan Time |
| PWM Out Maximum Frequency | 10kHz | |
| Rise Time | 2.4 μ s (typical @ 24V) | |
| Fall Time | 7.5 μ s (typical @ 24V) | |

Relay Outputs: Model R

| | |
|---|--|
| Outputs per Module | 6 Relay |
| Relay Contact Type | Floating |
| Max. Output Current & Voltage per Relay | 3A @ 60VAC, resistive 3A @ 30VDC, resistive |
| Max. Total Output Current | 5A continuous |
| Max. Switched Power | 150W |
| Contact Isolation to Ground | 1000VAC |
| Max. Voltage Drop at Rated Current | 0.5V |
| Expected Life | No Load: 10,000,000 cycles Rated Load: 100,000 cycles |
| Max. Switching Rate | 300 CPM at no load 20 CPM at rated load |
| Type | Mechanical Contact |
| Response Time | One update per ladder scan plus 10 ms |

ANALOG I/O SPECIFICATIONS

Analog Inputs, Models R & A

| | |
|--|---|
| Number of Channels | 4 |
| Input Ranges | 0-20mA; 4-20mA |
| Nominal Resolution | 12 Bits |
| Safe Input Voltage Range | -0.5V to 12V, protection up to 24V |
| Input Impedance (clamped @ -0.5VDC to 12VDC) | Current Mode: 100Ω |
| %AI Full Scale | 20mA : 32,000 full scale |
| Max. Over Current | 25mA |
| Max Error at 25°C (excluding Zero) Adjusting Filtering may Tighten | < 1.5% of full scale |
| Filtering | 160 Hz Hash (noise) Filter, 1-128 Scan Digital Running Average Filter |

Analog Outputs, Models R & A

| | |
|-------------------------------------|--|
| Number of Channels | 2 |
| Output Ranges | 4-20mA |
| Nominal Resolution | 12 Bits |
| Update Rate | Once per PLC scan |
| Max. Error at 25°C (Excluding Zero) | < 1.5% of full scale |
| Maximum 20mA Load | 500Ω |
| % AQ Full Scale | 32,000 |
| Protection | Protect against miswire up to 24VDC auto-recover |

WIRING: INPUTS AND OUTPUTS

Analog Inputs Information

Raw input values for channels 1-4 are found in the registers as Integer-type data with a range from 0 – 32000. Analog inputs may be filtered digitally with the Filter Constant found in the Cscape Hardware Configuration for Analog Inputs. Valid filter values are 0-7 and act according to the following chart:

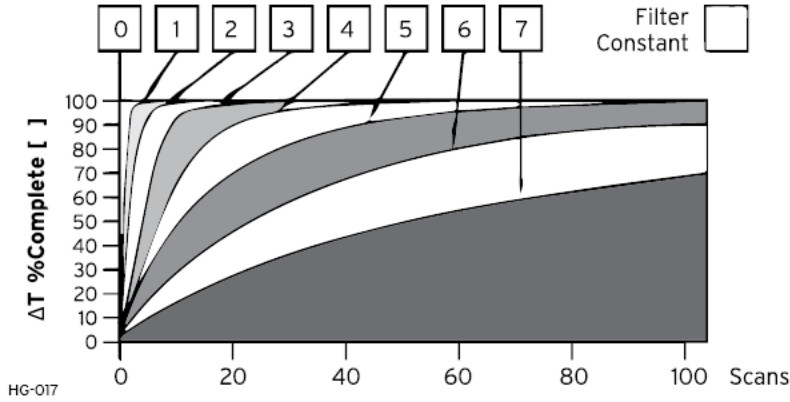

| Data Values | |
|----------------|--------------------------|
| Input Mode: | Data Format, 12-bit INT: |
| 0-20mA, 4-20mA | 0-32000 |

Digital Inputs

Positive Logic vs. Negative Logic

The OCS can be wired for positive logic inputs or negative

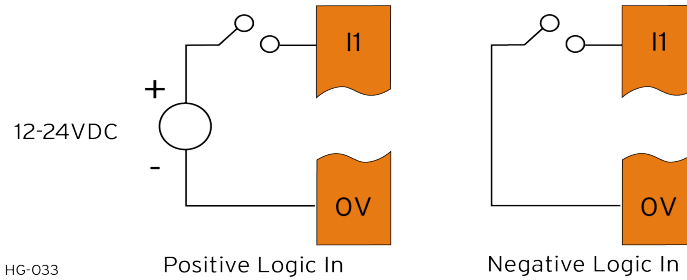

Digital inputs may be wired in either a Positive Logic or Negative Logic fashion as shown. The setting in the Cscape Hardware Configuration for the Digital Inputs must match the wiring used in order for the correct input states to be registered.

Inserting and Removing Connectors

To Insert: Using a small screwdriver, firmly press on connector on one end and then the other until connector clicks into place. Ensure connector is firmly seated.

To Remove: Use a small screwdriver on each side of connector to gently pry up the connector.

Built-In I/O: Models R & A

| Fixed Address | I/O Function | Model R | Model A |
|---------------|-----------------|---------|---------|
| %I | Digital Inputs | 1-12 | 1-12 |
| | Reserved | 13-32 | 13-32 |
| %Q | Digital Outputs | 1-2 | 1-12 |
| | Relay Outputs | 3-8 | -- |
| | Reserved | 9-16 | 13-16 |
| %AI | Analog Inputs | 1-4 | 1-4 |
| | Reserved | 5-12 | 5-12 |
| %AQ | Analog Outputs | 1-2 | 1-2 |
| | Reserved | 3-6 | 3-6 |

J1 & J2 WIRING

J1 Wiring: Model A - Digital Out

| Position | Pin | Digital Model |
|----------|------------|------------------|
| 1 | Q1 (%Q1) | Dig. Out 1 (PWM) |
| 2 | Q2 (%Q2) | Dig. Out 2 (PWM) |
| 3 | Q3 (%Q3) | Dig. Out. 3 |
| 4 | Q4 (%Q4) | Dig. Out. 4 |
| 5 | V+ | External V+ |
| 6 | C | Common |
| 7 | Q5 (%Q5) | Dig Out. 5 |
| 8 | Q6 (%Q8) | Dig Out. 6 |
| 9 | Q7 (%Q7) | Dig Out 7 |
| 10 | Q8 (%Q8) | Dig Out 8 |
| 11 | Q9 (%Q9) | Dig Out 9 |
| 12 | Q10 (%Q10) | Dig Out 10 |
| 13 | Q11 (%Q11) | Dig Out 11 |
| 14 | Q12 (%Q12) | Dig Out 12 |
| 15 | V+ | External V2+ |
| 16 | C | Common |

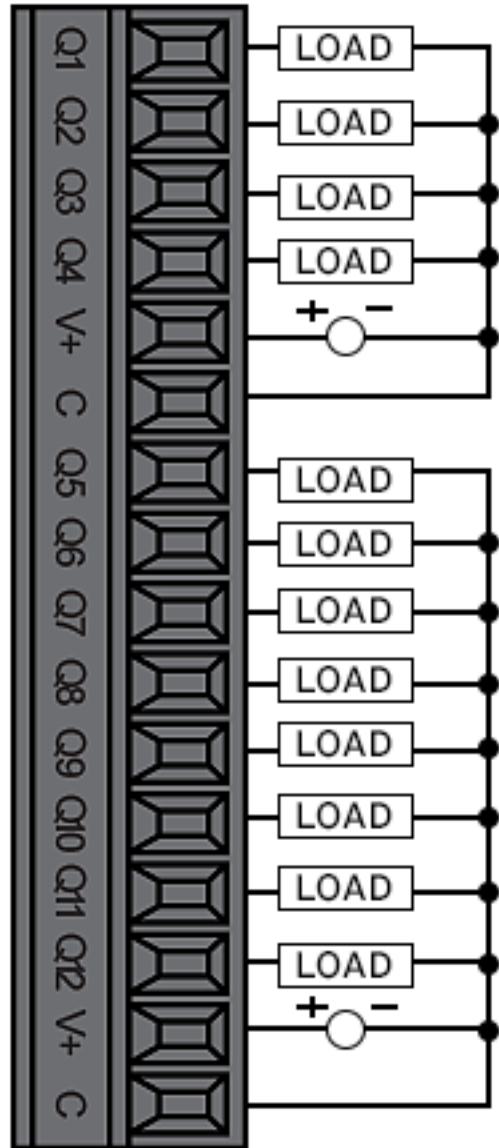

HG-047

J1 Wiring: Model R - Relay/Digital Out

| Position | Pin | Digital Model |
|----------|----------|---------------|
| 1 | R1 (%Q3) | Relay 1 N.O. |
| 2 | C1 | Relay 1 C |
| 3 | R2 (%Q4) | Relay 2 N.O. |
| 4 | C2 | Relay 2 C |
| 5 | R3 (%Q5) | Relay 3 N.O. |
| 6 | C3 | Relay 3 C |
| 7 | R4 (%Q6) | Relay 4 N.O. |
| 8 | C4 | Relay 4 C |
| 9 | R5 (%Q7) | Relay 5 N.O. |
| 10 | C5 | Relay 5 C |
| 11 | R6 (%Q8) | Relay 6 N.O. |
| 12 | C6 | Relay 6 C |
| 13 | Q1 (%Q1) | Output 1 |
| 14 | Q2 (%Q2) | Output 2 |
| 15 | V+ | External V+ |
| 16 | C | Common |

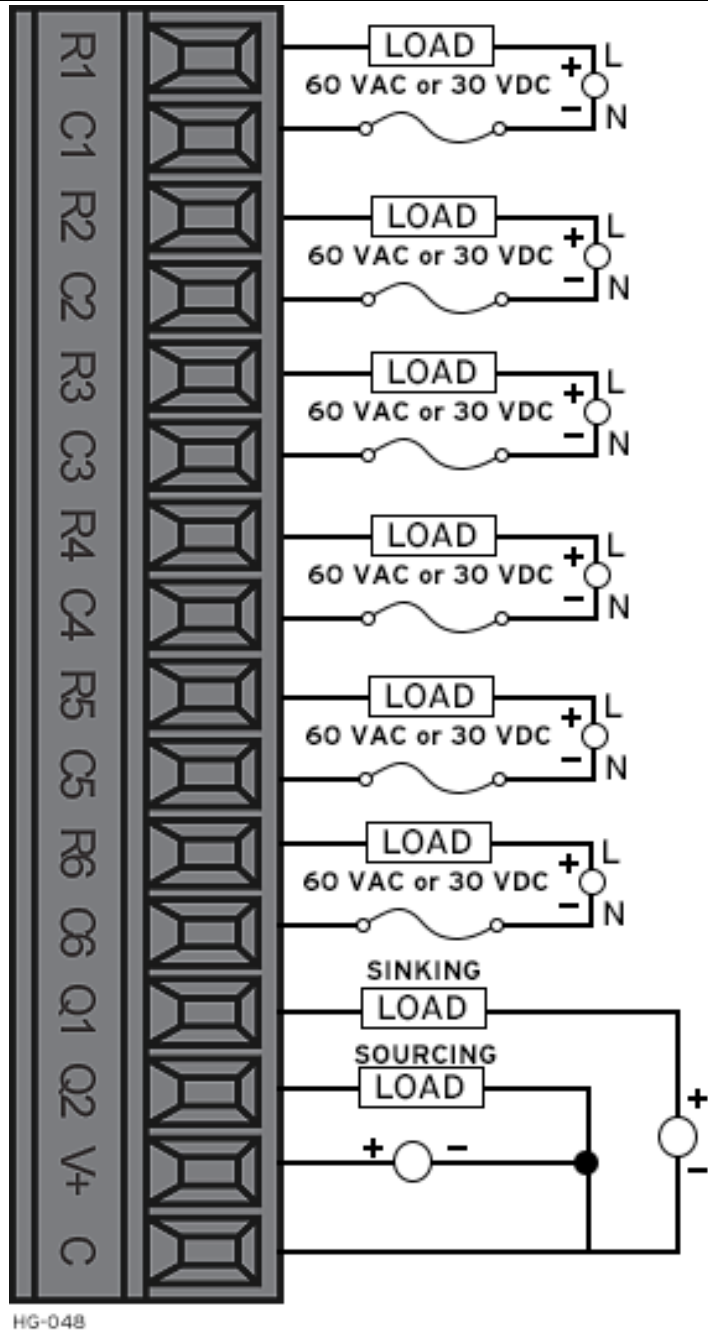

Sinking & Sourcing Wiring on Model R

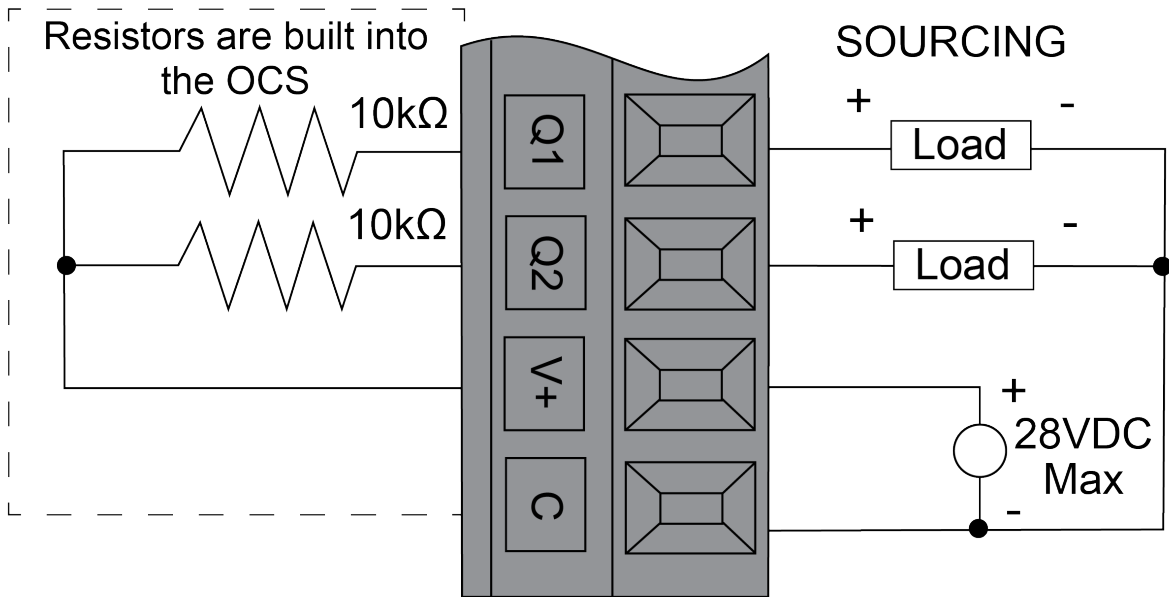

HG-206

Sourcing: 2.4mA sourcing @ 24V

NOTE: Cscape offers a choice to flip the output by selecting "sourcing" as the output mode. This can come in handy when working with certain devices in this setup. It's important to note that this option doesn't alter the kind of output.

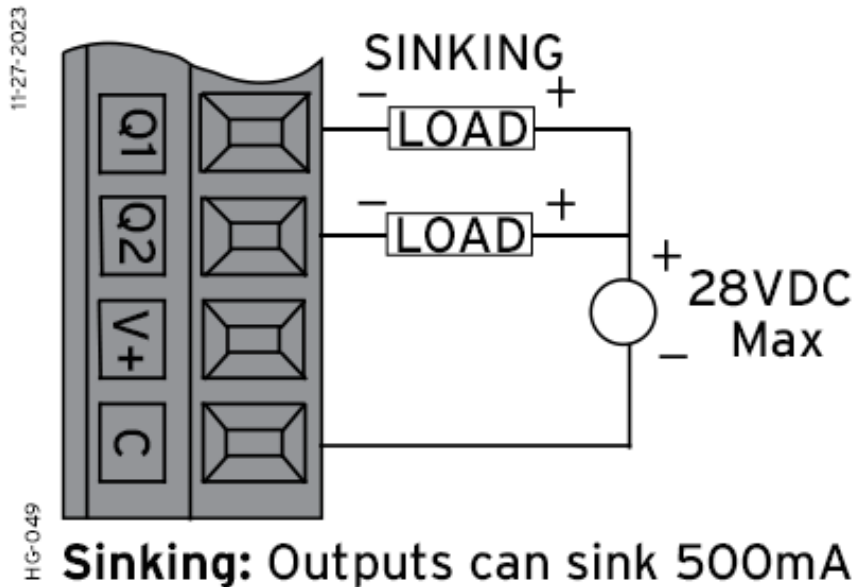

J2 Wiring: Models R & A - Digital Input

| Position | Pin | Digital Model |
|----------|------------|-----------------|
| 1 | I1 (%I1) | Dig. IN 1 (HSC) |
| 2 | I2 (%I2) | Dig. IN 2 (HSC) |
| 3 | I3 (%I3) | Dig. IN 3 (HSC) |
| 4 | I4 (%I4) | Dig. IN 4 (HSC) |
| 5 | I5 (%I5) | Dig. IN 5 |
| 6 | I6 (%I6) | Dig. IN 6 |
| 7 | I7 (%I7) | Dig. IN 7 |
| 8 | I8 (%I8) | Dig. IN 8 |
| 9 | I9 (%I9) | Dig. IN 9 |
| 10 | I10 (%I10) | Dig. IN 10 |
| 11 | I11 (%I11) | Dig. IN 11 |
| 12 | I12 (%I12) | Dig. IN 12 |
| 13 | C | Common |
| 14 | C | Common |

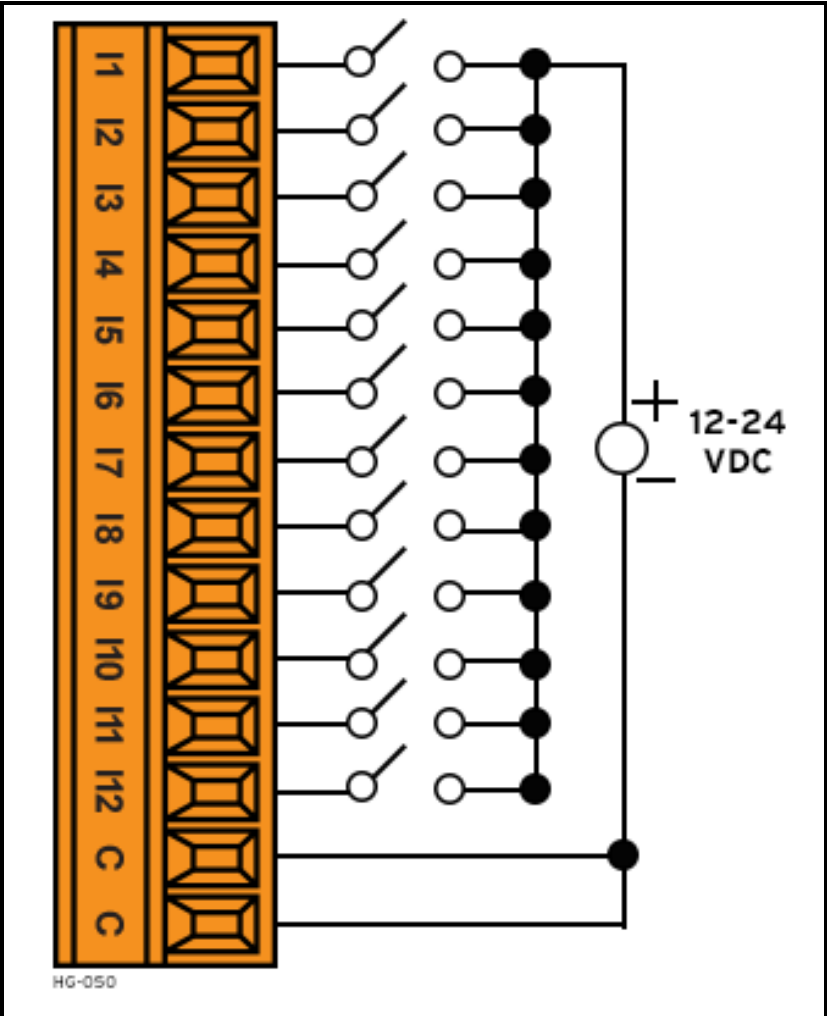

J3 WIRING

Models A & R: Analog I/O

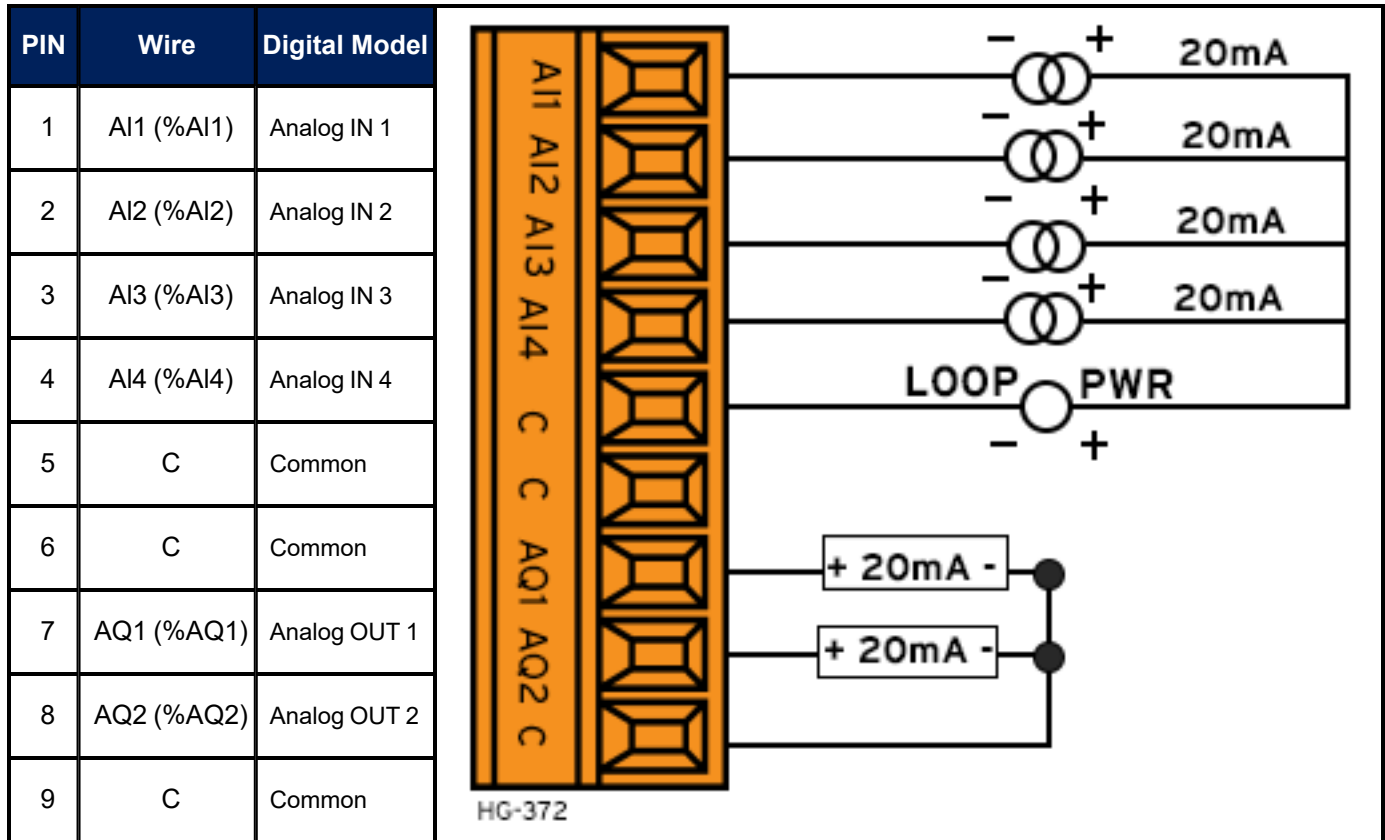

Universal Wiring Schematic

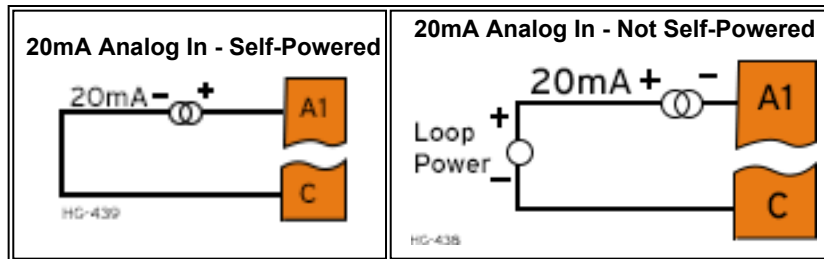

COMMUNICATIONS

Serial Communication

MJ1/2 Serial Ports

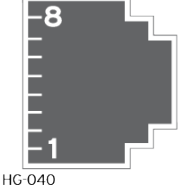
|  <p>2 Serial Ports on 1 Modular jack (8p8c)</p> <p>MJ1: RS-232 w/Full Handshaking MJ2: RS-485 Half-Duplex - RS-485 termination and biasing via System Menu or System Register</p> | MJ1 & MJ2 PINS | | |
|---|-----------------|-----------------|-----------|
| | PIN | SIGNAL | DIRECTION |
| | 8 | TXD (MJ1) | OUT |
| | 7 | RXD (MJ1) | IN |
| | 6 | 0V | COMMON |
| | 5 | +5V @ 60mA | OUT |
| | 4 | RTS (MJ1) | OUT |
| | 3 | CTS (MJ1) | IN |
| | 2 | RX-/TX-/- (MJ2) | IN/OUT |
| 1 | RX+/TX+/- (MJ2) | IN/OUT | |

NOTE: Attach optional Ferrite Core (HE-FBD001) with a minimum of two turns of serial cable.

Ethernet

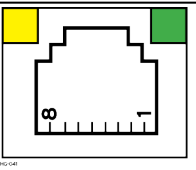
| | |
|--|---|
|  | <p>Green LED indicates link - when illuminated, data communication is available. Yellow LED indicates activity - when flashing, data is in transmission.</p> |
|--|---|

CAN Communications

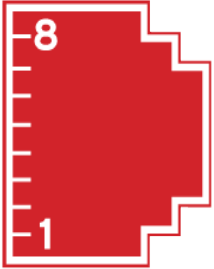
|  HG-042 | Modular jack (8p8c) | CAN Pin Assignments | |
|---|---------------------|---------------------|-----------------------------|
| | | PIN | SIGNAL |
| | | 8 | No Connection |
| | | 7 | Ground (PCB Ground) |
| | | 6 | [CAN] Shield (Earth Ground) |
| | | 5 | No Connection |
| | | 4 | No Connection |
| | | 3 | Ground (PCB Ground) |
| | | 2 | CAN Data Low |
| | | 1 | CAN Data High |

The CAN port is provided via the single 8-position modular jack labeled “CAN”. It may be used to communicate with other OCS products using Horner’s CsCAN protocol. Additionally, remote expansion I/O such as SmartRail, SmartBlock, and SmartStix may be implemented using the CsCAN protocol.

Termination for the CAN port may be enabled from the System Menu or System Register. This should only occur if this device is at either end of the CAN network. Only the two devices on either end of the CAN network should be terminated.

Discrete Wiring

For CAN or serial connections the [HE200MJ2TRM](#) accessory will provide a modular connector to wiring block adapter for installations that require discrete wiring.



HG-043

DIMENSIONS & INSTALLATION

X2 Dimensions

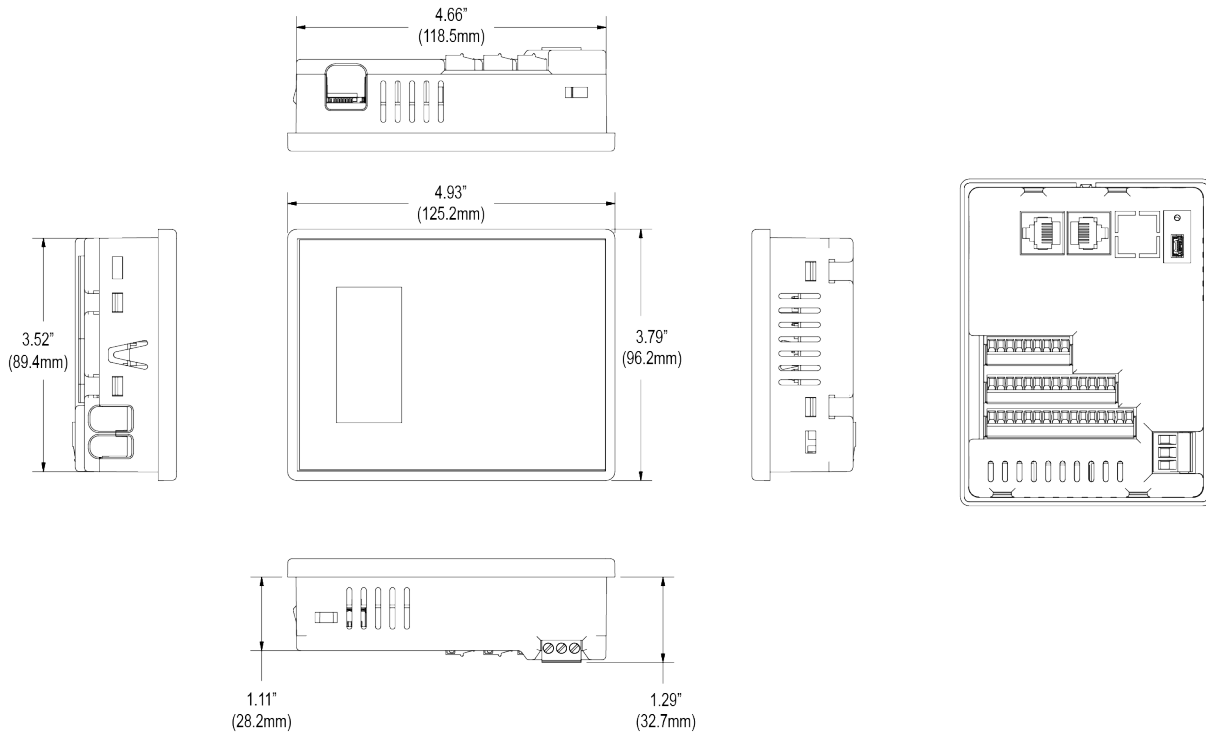

HG-467

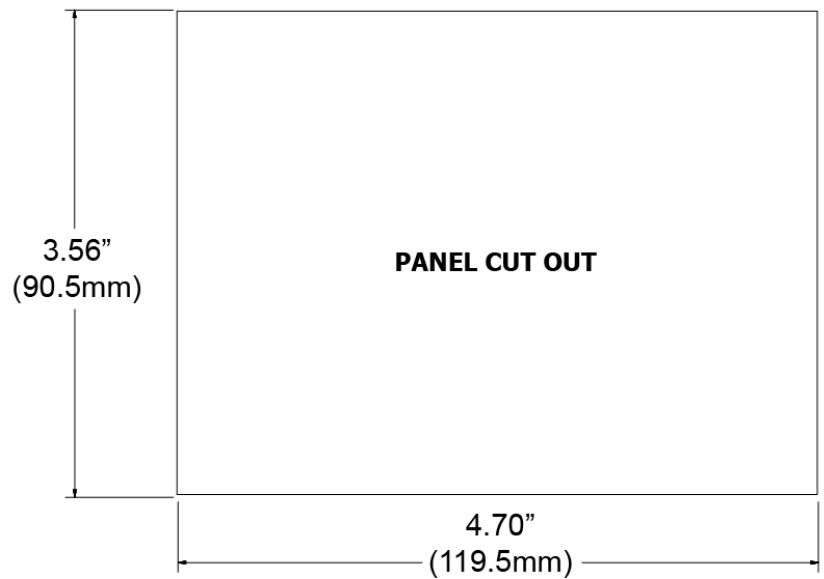

+ 0.5mm / -0mm Cutout Tolerance

Installation Procedure

- This equipment is panel mounted and is meant to be installed in an enclosure suitable for the environment, such that the back of the equipment is only accessible with the use of a tool.
- Requires a Class 2 power source.
- This equipment is suitable for use in Class I, Division 2, Groups A, B, C and D; Class II, Division 2 Groups F and G; and Class III Hazardous Locations or Non-Hazardous Locations only.
- The X2 utilizes a clip installation method to ensure a robust and watertight seal to the enclosure. Follow the steps below for the proper installation and operation of the unit.

Please following the steps below for the proper installation and operation of the unit.

1. Carefully locate an appropriate place to mount the X2. Be sure to leave enough room at the top of the unit for insertion and removal of the microSD™ card.
2. Carefully cut the host panel per the diagram, creating a 91mm x 118.75mm +/-0.1mm opening into which the X2 is to be installed. If the opening is too large, water may leak into the enclosure, potentially damaging the unit. If the opening is too small, the OCS may not fit through the hole without damage.
3. Remove any burrs/sharp edges and ensure the panel is not warped in the cutting process.
4. Install and tighten the four mounting clips (provided in the box) until the gasket forms a tight seal.

NOTE: For standard composite mounting clips (included with product), use a torque rating of 2-3 in-lbs (0.23-0.34Nm). For optional metal mounting clips, use a torque rating of 4-8 in-lbs (0.45-0.90 Nm).

5. Connect communications cables to the serial port, USB ports, and CAN port as required.

SAFETY & MAINTENANCE

Warnings

1. To avoid the risk of electric shock or burns, always connect the safety (or earth) ground before making any other connections.
2. To reduce the risk of fire, electrical shock, or physical injury, it is strongly recommended to fuse the voltage measurement inputs. Be sure to locate fuses as close to the source as possible.
3. Replace fuse with the same type and rating to provide protection against risk of fire and shock hazards.
4. In the event of repeated failure, do **NOT** replace the fuse again as repeated failure indicates a defective condition that will **NOT** clear by replacing the fuse.
5. Only qualified electrical personnel familiar with the construction and operation of this equipment and the hazards involved should install, adjust, operate, or service this equipment.
6. Read and understand this manual and other applicable manuals in their entirety before proceeding. Failure to observe this precaution could result in severe bodily injury or loss of life.
7. **WARNING:** Battery may explode if mistreated. Do not recharge, disassemble, or dispose of in fire.
8. **WARNING:** EXPLOSION HAZARD- Batteries must only be changed in an area known to be non-hazardous.
9. **WARNING:** Do not disconnect while circuit is live unless area is know to be non-hazardous.

FCC Compliance

This device complies with Part 15 of the FCC Rules. Operation is subject to the following two conditions:

1. This device may not cause harmful interference.
2. This device must accept any interference received, including interference that may cause undesired operation.

Precautions

All applicable codes and standards need to be followed in the installation of this product. Adhere to the following safety precautions whenever any type of connection is made to the module:

1. Connect the safety (earth) ground on the power connector first before making any other connections.
2. When connecting to the electric circuits or pulse-initiating equipment, open their related breakers.
3. Do NOT make connection to live power lines.
4. Make connections to the module first; then connect to the circuit to be monitored.
5. Route power wires in a safe manner in accordance with good practice and local codes.
6. Wear proper personal protective equipment including safety glasses and insulated gloves when making connections to power circuits.
7. Ensure hands, shoes, and floor are dry before making any connection to a power line.
8. Make sure the unit is turned OFF before making connections to terminals.
9. Make sure all circuits are de-energized before making connections.
10. Before each use, inspect all cables for breaks or cracks in the insulation. Replace immediately if defective.
11. Use copper conductors in field wiring only, 60/75°C.



- 12. Use caution when connecting controllers to PCs via serial or USB. PCs, especially laptops, may use “floating power supplies” that are ungrounded. This could cause a damaging voltage potential between the laptop and controller. Ensure the controller and laptop are grounded for maximum protection. Consider using a USB isolator due to voltage potential differences as a preventative measure.

Technical Support

| North America | Europe |
|--|--|
| 1 (317) 916-4274 1 (877) 665-5666 www.hornerautomation.com APGUSATechSupport@heapg.com | +353 (21) 4321-266 www.hornerautomation.eu technical.support@horner-apg.com |